

 **BLAUPUNKT**



VELOCITY POWER  
ACTIVE SUBWOOFER  
**XLf 220 A**



*Enjoy it.*

**Operating and Installation Instructions**

## CAUTIONS

Proper system planning is vital in order to maximize the device's performance and road safety. Plan your installation carefully to avoid compromising performance reliability of the system. Consult an authorized Blaupunkt dealer for installation or repair. Read the manual carefully before operating the device for the first time.

### Safety Notes

Ensure to follow below safety notes during installation and wiring connection :-

- Disconnect the negative terminal of the battery. Refer to the safety notes of vehicle manufacturer.
- Ensure positions of the holes are nowhere near the vehicle component to avoid any damage during drilling.
- Ensure cross section of the cable is no less than 2.5mm<sup>2</sup> if the positive and negative cables are too long.
- Incorrect installation may result in malfunction of the device or the car sound system.

### Installation and Connection Instructions

- Select a dry and well-ventilated location to install the device.
- The device must not be installed in overly exposed location such on the rear shelf, rear seat etc.
- The installation location must be suitable for screw holes and have stable ground support.

### Voltage Supply

- Use the supplied power extension cable to connect to the positive battery terminal.
- Firmly and carefully connect the ground lead to a bare metal point on the vehicle chassis.
- The control of the device should be a two-channel control, either via the preamplifier outputs or the loudspeaker, output of the car sound system.
- A control solely via the right or left channel is also possible since the low-frequency portion of the music is generally identical on both channels.

### Integrated Fuse

The integrated fuse in the device protects the output voltage and the entire electrical system in case of malfunction. Do not replace damaged fuse with higher current.

### Switching On/Off

This device will automatically turn on if a music signal is detected. The device will also automatically turn off if no music signal is received.

### Remote Control



- Gain adjustment :
- Turn the gain knob to adjust the volume to the desired level.

### Disclaimer

In no event shall Blaupunkt be liable for any direct, indirect, punitive, incidental, special consequential damages to property or life and whatsoever arising out of or connected with the use or misuse of our products.

USA & CANADA: This product is not intended for sale in the United States and Canada. If purchased in the U.S. or Canada, this product is purchased on as-is basis. No warranty, whether expressed or implied is provided in the U.S. or Canada.

### Recycling and Disposal



Do not dispose of your old unit in the household trash!  
Use the return and collection systems available to dispose of the old device.

This manual may be updated from time to time without any notice.

## FUNCTIONS CONTROLLING DIAGRAM

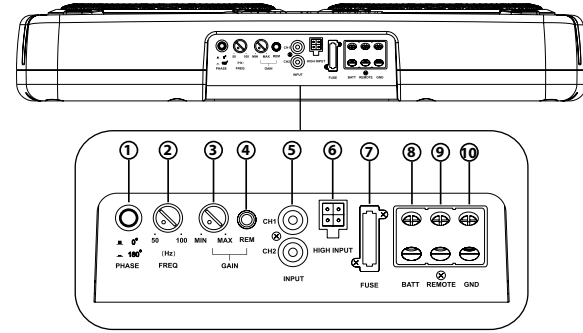

1. Phase (0° ~ 180°)
2. Frequency (50Hz ~ 100 Hz)
3. Input Gain (200mV ~ 6V)
4. Remote Control
5. RCA Input (LCH, RCH)
6. High Input
7. Fuse (15A)
8. +12V Battery
9. Remote (Turn-on)
10. Ground (Chassis)

## SPECIFICATION

### Dual Subwoofer

- Speaker Size : 8"
- Cone Composition : Aluminium
- Magnet Type : Ferrite
- Enclosure Housing Material : Aluminium
- Enclosure Dimension (L x W x H) : 504 x 340 x 85mm
- Enclosure Net Weight : 5kg

### Amplifier

- Amplifier Technology : Class AB
- Normal Output Power (RMS) : 220W
- Max Output Power : 550W
- Audio in Sensitivity : RCA input 82mV, Speaker input 0.8V
- Signal/Noise Ratio : 91dB
- Output Impedance : Dual (2 ohms+2 ohms)
- Frequency Response : 30Hz-150Hz
- Low Pass Filter (LPF) : 50Hz-100Hz

- Voltage : 14.4V (10V-16V)
- Phase Switch : 0° / 180°
- Automatic On/Off : High Level Only
- Fuse Rating : 15A
- Gain : 200mV ~ 6V
- Thermal Short & Overload Protection Circuits : Included

### Accessories

- Remote Controller : Wired
- Screws (Parker-Type) : 14 x (M5 x 18mm)
- Screws (M-Type) : 4 x (M4 x 50mm)
- Overall Net Weight : 9kg (Without accessories)

# INSTALLATION POSITION

## SIDE FIRING POSITION



## UP FIRING POSITION

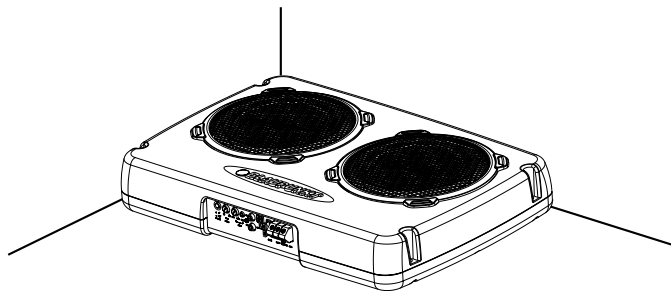

# WIRING DIAGRAM

Use the supplied cable and wire harness to connect the outputs correctly by referring to Diagram 1 & Diagram 2.

### Diagram 1 (High Level Input -Speaker Input)

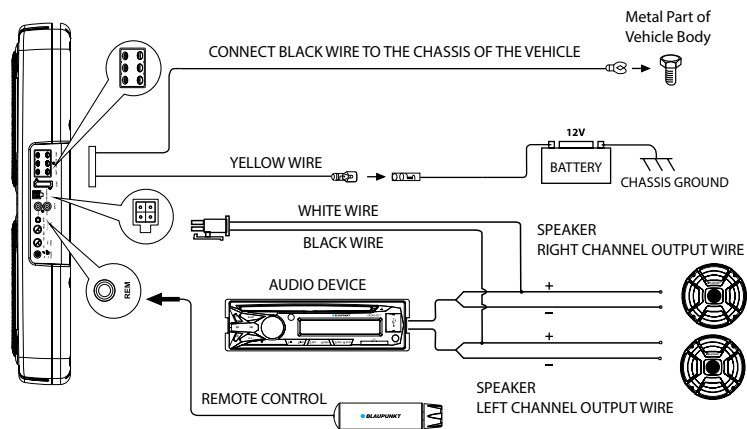

### Diagram 2 (Low Level Input -Speaker Input)

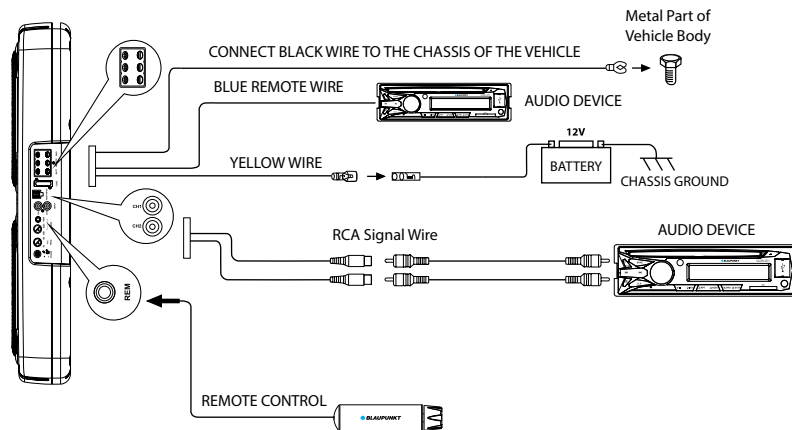

## TROUBLESHOOTING

If any of the following problem occur, please resort to Troubleshooting for the possible solutions. Consult Blaupunkt authorized dealer if problem persist.

Problems	Solutions
Power up failure	Examine if the ground connection is intact.
	Examine if remote input has at least 5V DC.
	Examine if battery power is connected correctly to the + terminal.
	Ensure supplied voltage is minimum 12V.
	Examine if fuse is broken and replace if necessary.
Restart the device if protection LED light is on.	
Protection LED lights on when turn on	Examine speaker wire had short-circuit.
	Turn volume down from head unit to prevent overdriving the device.
	Device might need service or repair, if protection LED light is still on after resetting the device.
No sound output	Examine fuses and replace if necessary.
	Examine ground connection if intact.
	Examine if remote input has at least 5V DC.
	Examine if RCA audio cables are connected to the right inputs.
Examine if speaker wiring is intact.	
Low sound output	Reset Level Control
	Examine the Crossover Control setting.
Buzzing noise	Observe if the device is still producing noise after turning on and o the amplifier. If yes, examine if the cables are correctly connected and if the cables and radio are in good condition. Repair or replace if the cables or the radio are not in good condition.
Squealing noise interference	Ensure RCA connections are properly connected.
Distorted sound output	Ensure input level of the device matches the signal level of the head unit.
	Always set the input level to the lowest.
	Examine if crossover frequency is set correctly.
	Examine if speaker wire had short-circuit.
Temperature increased	Examine if minimum speaker impedance for the device is correct.
	Ensure good air ventilation around the device. Add external cooling fan if necessary.
Engine noise (static sound) interference	Usually caused by poor RCA cable quality, which release noise. Use only the best quality cables, and route them away from power cables.
Engine noise (alternator whine) interference	Examine if RCA cable are nowhere near or attached to the vehicle chassis.
	Examine if head unit is properly connected to the wires.

