

 **BLAUPUNKT**



# ACTIVE SUBWOOFER **GTr 110 A**



*Enjoy it.*

**Operating and Installation Instructions**

# INTRODUCTION

Proper system planning is vital in order to maximize the device's performance and road safety. Plan your installation carefully to avoid compromising performance reliability of the system. Consult an authorized Blaupunkt dealer for installation or reparation. Read the manual carefully before operating the device for the first time.

### Safety Notes

Ensure to follow below safety notes during installation and wiring connection :-

- Disconnect the negative terminal of the battery. Refer to the safety notes of vehicle manufacturer. Ensure positions of the holes are nowhere near the vehicle component to avoid any damage during drilling. Incorrect installation may result in malfunction of the device or the car sound system.

### Installation and Connection Instructions

- Select a dry and well-ventilated location to install the device.
- The device must not be installed on the rear shelf, rear seats or exposed locations.
- The installation location must be suitable for screw holes and have stable ground support.

### Integrated Fuse

- The integrated fuse in the device protects the output voltage and the entire electrical system in case of malfunction. Do not replace damaged fuse with higher current.

### Switching On/Off

- This device will automatically turn on if audio signal is detected. The device will also automatically turn off if audio signal is received.

### Disclaimer

- In no event shall Blaupunkt be liable for any direct, indirect, punitive, incidental, special consequential damages, to property or life, improper storage, whatsoever arising out of or connected with the use or misuse of our products.
- USA & CANADA : Product not intended for sale in the United States and Canada. If purchased in the U.S. or Canada, this product is purchased as-is. No warranty, express or implied is provided in the U.S. and Canada.

### Remote Control

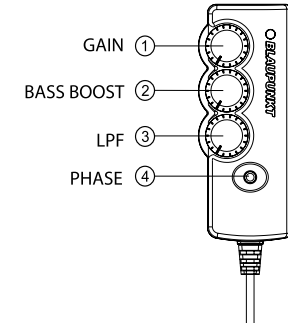

- 1 Set the GAIN to 200mV (Min), PHASE to NORM., LOW PASS FILTER to Center before turning on the device. Set the Bass/Treble of head unit to zero. Set volume to lower level.
- 2 Gradually increase GAIN until the desired sound effect is achieved or until the sound distribution in the vehicle is even.
- 3 Avoid setting volume of the head unit and GAIN too high to prevent sound distortion. Ensure speakers are functioning well to avoid sound distortion too. Then adjust the LOW PASS FILTER (L.P.F.) to the desired frequency.
- 4 Changing the LPF will change the sound output of the subwoofer. Continue to adjust GAIN, LPF and volume until the desired setting is found.
- 5 Play the music from the head unit while sitting at the driver and switch between NORM and REV to select the desired sound output setting. The ideal PHASE is subjective and varies from one vehicle to another, depending on the location of the device and the acoustic characteristics of the vehicle interior.
- 6

### Recycling and Disposal



Do not dispose of your old unit in the household trash!  
Use the return and collection systems available to dispose of the old device.

This manual may be updated from time to time without any notice.

## INSTALLATION

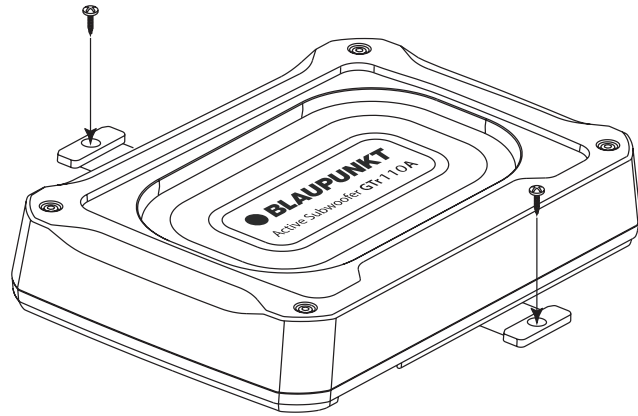

## SPECIFICATION

### Subwoofer

- Speaker Size : 214.5mm x 135.0mm
- Cone Composition : Aluminium
- Magnet Type : Ferrite
- Wired Remoted : Included
- Enclosure Housing Material : Plastic & Aluminium
- Enclosure Dimension (LxWxH) : 280 x 200 x 74mm
- Enclosure Net Weight : 2.89kg

### Amplifier

- Amplifier Technology : Class AB
- Normal Output Power (RMS) : 110W
- Max. Output Power : 250W
- Sensitivity (In Car/1W) : 92dB
- Signal / Noise Ratio (dB) : 91dB
- Impedance : 2.2 +2.2 ohms
- Frequency Response : 40Hz – 150Hz
- Low Pass Filter (LPF) : 83Hz – 150hz
- Voltage : 14.4 (10V – 16V)
- Phase Switch : 0 deg / 180 deg
- Automatic On/Off (Hi & Lo) : High Level Only

### Accessories

- Remote Controller : Wired Remote
- Screws (Parker-Type) : 5 x 15mm
- Screws (M-Type) : 4 x 8mm
- 2 x Mounting Bracket A : 72mm x 40mm
- Wiring Harness (300m DC Cord, High Level Input Speaker Wires, Low Level Input Speaker Wires & Input Plug Wires)

## WIRING DIAGRAM

Use the supplied cable and wire harness to connect the outputs correctly by referring to Diagram 1 & Diagram 2.

Diagram 1 (High Level Input -Speaker Input)

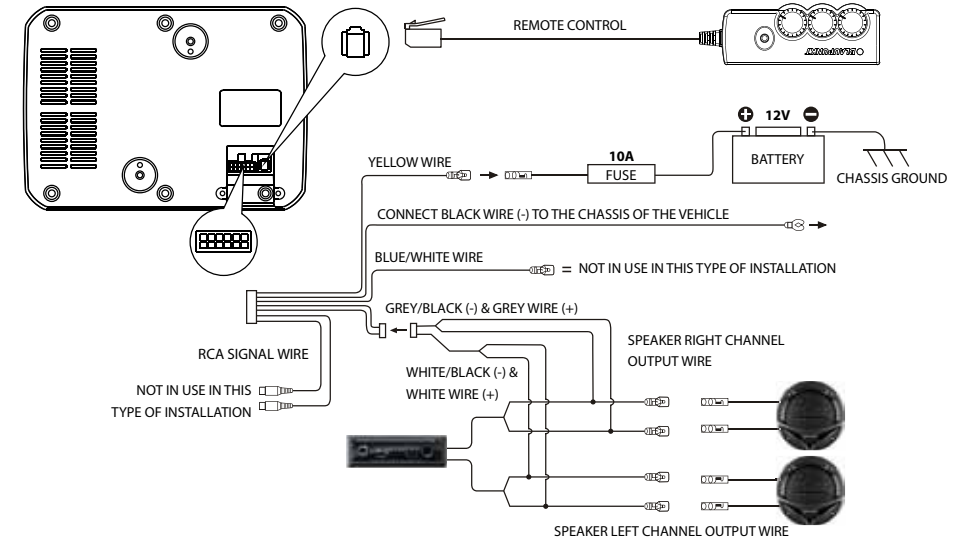
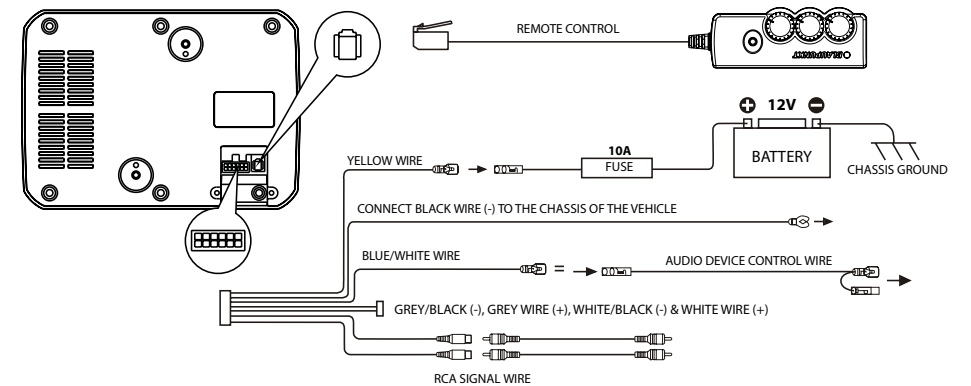

Diagram 2 (Low Level Input -Speaker Input)



## TROUBLESHOOTING

If any of the following problem occur, please resort to Troubleshooting for the possible solutions. Consult Blaupunkt authorized dealer if problem persist.

Problems	Solutions
Amplifier power up failure	Examine if the ground connection is intact.
	Examine if remote input has at least 5V DC.
	Examine if battery power is connected correctly to the + terminal.
	Ensure supplied voltage is minimum 12V.
	Examine if fuse is broken and replace if necessary.
No sound output	Restart the device if protection LED light is on.
	Examine fuses and replace if necessary.
	Examine ground connection is intact.
	Examine if remote input has at least 5V DC.
	Examine if RCA audio cables are connected to the right inputs.
Low sound output	Examine if speaker wiring is intact.
	Reset Level Control
Buzzing noise	Examine the Crossover Control setting.
	Observe if the device is still producing noise after turning on and off the amplifier. If yes, examine if the cables are correctly connected and if the cables and radio are in good condition. Repair or replace if the cables or the radio are not in good condition.
Squealing noise interference	Ensure RCA connections are properly connected.
Distorted sound output	Ensure input level of the device matches the signal level of the head unit.
	Always set the input level to the lowest.
	Examine if crossover frequency is set correctly.
	Examine if speaker wire had short-circuit.
Amplifier temperature increased	Examine the minimum speaker impedance for the amp models is correct.
	Ensure good air ventilation around the device. Add external cooling fan if necessary.
Engine noise (static sound) interference	Usually caused by poor RCA cable quality, which release noise. Use only the best quality cables, and route them away from power cables.
Engine noise (alternator whine) interference	Examine if RCA cable are nowhere near or attached to the vehicle chassis.
	Examine if head unit is properly connected to the wires.

