

 **BLAUPUNKT**

BLAUPUNKT
Brand
established
1924
GERMANY 

VELOCITY POWER
ACTIVE SUBWOOFER
XLf 320 AW



Enjoy it.

Operating and Installation Instructions

INTRODUCTION

Proper system planning is vital in order to maximize the device's performance and road safety. Plan your installation carefully to avoid compromising performance reliability of the system. Consult an authorized Blaupunkt dealer for installation or repair. Read the manual carefully before operating the device for the first time.

Safety Notes

Ensure to follow below safety notes during installation and wiring connection :-

- Ensure positions of the holes are nowhere near the vehicle component to avoid any damage during drilling.
- Ensure cross section of the cable is no less than 2.5mm² if the positive and negative cables are too long.
- Incorrect installation may result in malfunction of the device or the car sound system.

Installation and Connection Instructions

- Select a dry and well-ventilated location to install the device.
- The device must not be installed in overly exposed location such on the rear shelf, rear seat
- etc.
The installation location must be suitable for screw holes and have stable ground support.

Voltage Supply

- Use the supplied power extension cable to connect to the positive battery terminal.
- Firmly and carefully connect the ground lead to a bare metal point on the vehicle chassis.
- The control of the device should be a two-channel control, either via the preamplifier outputs or the loudspeaker, output of the car sound system.
- A control solely via the right or left channel is also possible since the low-frequency portion of the music is generally identical on both channels.

Integrated Fuse

The integrated fuse in the device protects the output voltage and the entire electrical system in case of malfunction. Do not replace damaged fuse with higher current.

Switching On/Off

This device will automatically turn on if a music signal is detected. The device will also automatically turn off if no music signal is received.

Remote Control

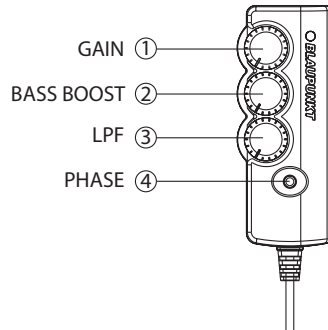

Disclaimer

In no event shall Blaupunkt be liable for any direct, indirect, punitive, incidental, special consequential-damages to property or life and whatsoever arising out of or connected with the use or misuse of our products.

USA & CANADA: This product is not intended for sale in the United States and Canada. If purchased in the U.S. or Canada, this product is purchased on as-is basis. No warranty, whether expressed or implied is provided in the U.S. or Canada.

Recycling and Disposal



Do not dispose of your old unit in the household trash!
Use the return and collection systems available to dispose of the old device.

This manual may be updated from time to time without any notice.

FUNCTIONS CONTROLLING DIAGRAM

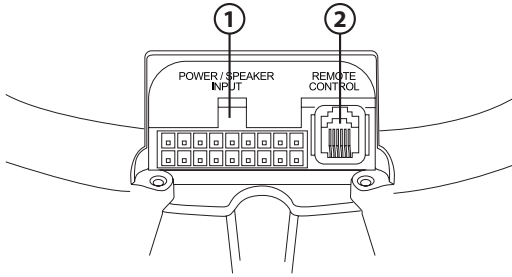

1. Power / Speaker Input
2. Remote Control Input

INSTALLATION INSTRUCTION

Threaded rods are available in 3 size : M8x125, M8x65 & M8x30. Please select suitable rods for installation according to the width of the tire.

Type 1 Fixing Base

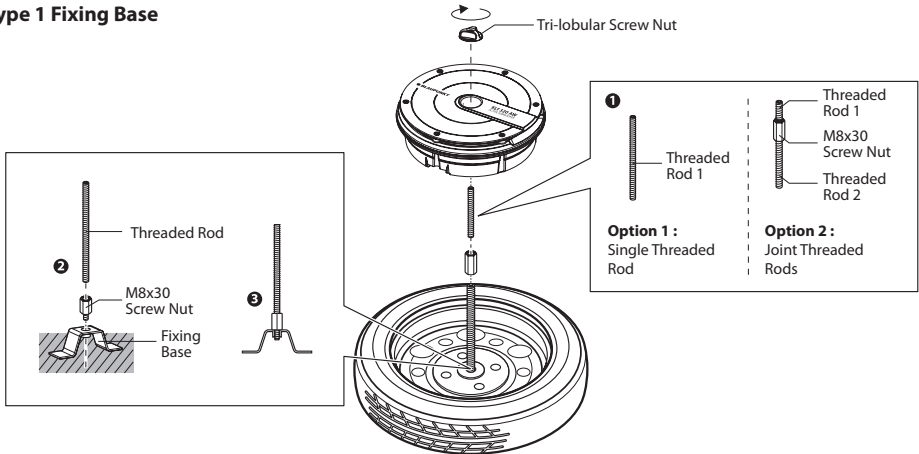

Type 2 Fixing Base

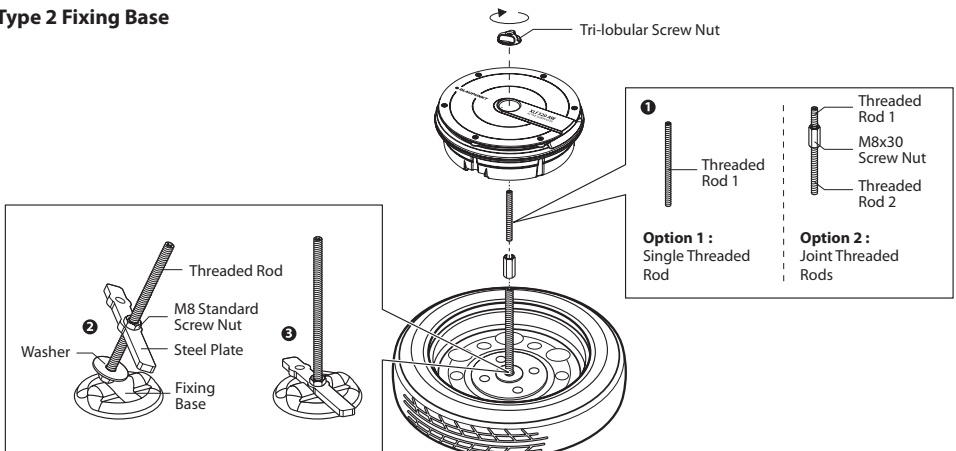

SPECIFICATION

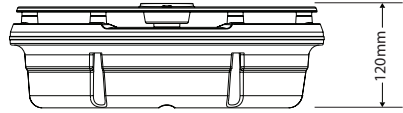
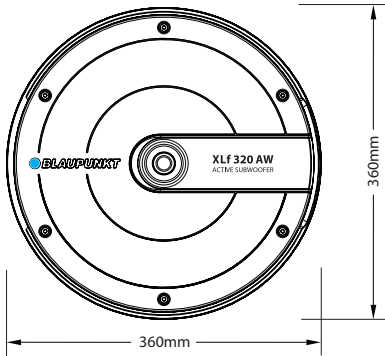

Subwoofer

- Speaker Size : 11" Diameter
- Impedance : (4+4) Ohms
- Sensitivity (1W/1m) : 85dB
- Cone Composition : Injected PP
- Magnet Type : Ferrite
- Enclosure Housing Material : Aluminum
- Enclosure Dimension (L x W x H) : 360 x 360 x 120mm
- Enclosure Net Weight : 7.4kg (Without Accessories)

- Max. Output Power : 420W
- Signal / Noise Ratio : >90dB
- Frequency Response : 20Hz - 150 Hz
- Low Pass Filter (LPF) : 50Hz - 150Hz
- Voltage : 12V (10V-14V)
- Phase Switch : 0 deg / 180 deg
- Automatic On/Off : High Level Only
- Fuse Rating : 30A
- THD : <0.4%
- Variable Bass Boost : 0 - 12dB
- Thermal Short & Overload Protection

Amplifier

- Amplifier Technology : D Class
- Normal Output Power (RMS) : 320W

Accessories



M8x125 Threaded Rod x1



M8x65 Threaded Rod x1



M8x30 Threaded Rod x1



M8x30 Screw Nut x2



4.5m Wired Remote Controller x1



Cable Holder Bar x1



Screws (M3x6) x2



M8 Standard Screw Nut x3



0.35m DC Cord x1



5mm Steel Plate x1



M8 Tri-lobular Screw Nut x1



30x 1.5mm Washer x1

WIRING DIAGRAM

1. Use the supplied cable and wire harness to connect the outputs correctly by referring to Diagram 1 & Diagram 2. Use only one of the audio inputs, otherwise, it may lead to audio interference.

Diagram 1 (High Level Input -Speaker Input)

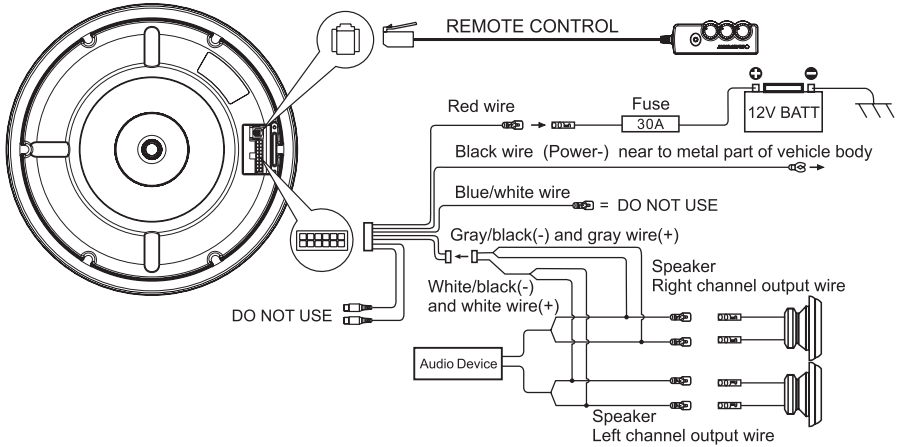

With control via the High Level Inputs, first the speaker harness will need to be spliced the wire side of the splitter. Then connect the white wire to the left (+), white/black wire to the left(-) (it can be identified whether the left or right channel via the attached harness label), grey to the right (+), and grey/black to the right (-) corresponding vehicles wires, and finally plug the supplied harness into the High-Level Inputs/power matching connector on the amplifier panel of the subwoofer.

Diagram 2 (Low Level Input -Speaker Input)

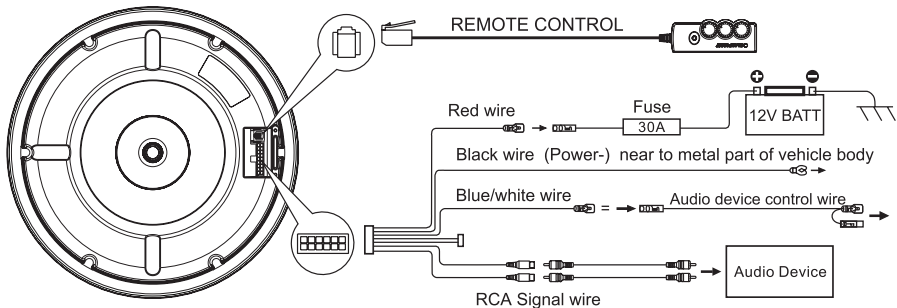

With control via the Low Level Inputs (also referred to as RCA Inputs), connect the blue colour remote wire from XLf 320 AW to the vehicle's head unit so XLf 320 AW will turn on and off with systems.

WIRING DIAGRAM

2. Securely mount the subwoofer to chassis with the provided bolt. (Fastener assemble direction has been enclosed.)

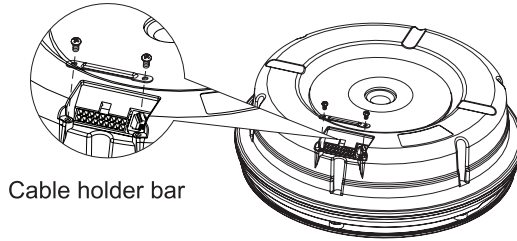

3. After the connection, place in the spare wheel active subwoofer to the right location, make sure the subwoofer been firmly press down.

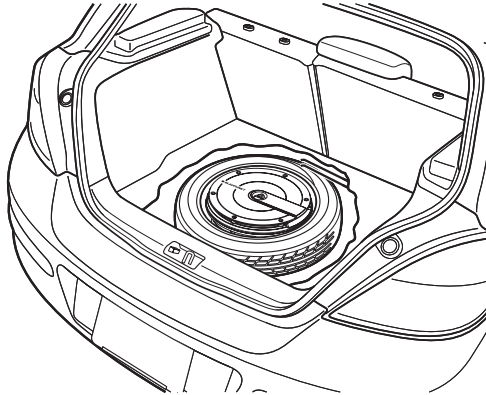

4. Set the bolt tightly to ensure the subwoofer firmly fixed with the car, at the same time can prevent the screw of spare tire dislocation.

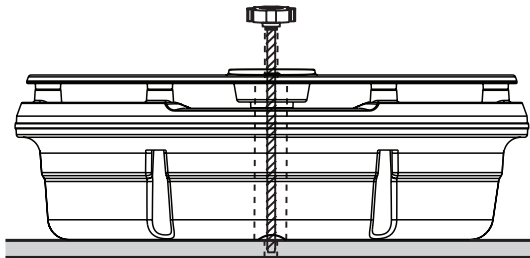

TROUBLESHOOTING

If any of the following problem occur, please resort to Troubleshooting for the possible solutions. Consult Blaupunkt authorized dealer if problem persist.

Problems	Solutions
Power up failure	Examine if the ground connection is intact.
	Examine if remote input has at least 5V DC.
	Ensure supplied voltage is minimum 12V.
	Examine if fuse is broken and replace if necessary.
Protection LED lights on when turn on	Restart the device if protection LED light is on.
	Examine speaker wire if had short-circuit.
	Turn volume down from head unit to prevent overdriving the device.
	Device might need service or repair, if protection LED light is still on after resetting the device.
No sound output	Examine fuses and replace if necessary.
	Examine ground connection if intact.
	Examine if remote input has at least 5V DC.
	Examine if RCA audio cables are connected to the right inputs.
Low sound output	Examine if speaker wiring is intact.
	Reset Level Control
Buzzing noise	Observe if the device is still producing noise after turning on and off the amplifier. If yes, examine if the cables are correctly connected and if the cables and radio are in good condition. Repair or replace if the cables or the radio are not in good condition.
	Ensure RCA connections are properly connected.
Squealing noise interference	Ensure input level of the device matches the signal level of the head unit.
Distorted sound output	Always set the input level to the lowest.
	Examine if speaker wire had short-circuit.
Temperature increased	Examine if minimum speaker impedance for the device is correct.
	Ensure good air ventilation around the device. Add external cooling fan if necessary.
Engine noise (static sound) interference	Usually caused by poor RCA cable quality, which release noise. Use only the best quality cables, and route them away from power cables.
Engine noise (alternator whine) interference	Examine if RCA cable are nowhere near or attached to the vehicle chassis.
	Examine if head unit is properly connected to the wires.

