

● **BLAUPUNKT**

ACTIVE SUBWOOFER

TWb 1000A

10" (250 mm) | 480 WATTS MAX. POWER



Enjoy it.

TWb 1000A

Introduction

Please read these operating instructions before using the equipment for the first time. We provide a manufacturer's warranty for products bought within the India and installed by a professional installer.

Safety Notes

Please observe the following safety notes during the installation and connection.

- Disconnect the negative pole of the battery! Observe the safety notes of the vehicle manufacturer
- When you drill holes, ensure that you do not damage any vehicle components.
- If the positive and negative cable are extended, ensure that the cross section is not less than 6 mm².
- An incorrect installation can result in malfunctions of the electronic vehicle systems or your car sound system.

Installation and connection instructions

With respect to accident safety, the TWb 1000A must be secured in a professional way.

When selecting the installation location, select a dry location that offers sufficient air circulation for cooling the amplifier.

The TWb 1000A must not be installed on rear shelves, rear seats or other locations that can cause harm in case of an accident while vehicle is in motion. It must be securely fastened in the trunk of the vehicle.

The amplifier power cable must be fitted with a fuse no more than 30 cm from the battery to protect the vehicle battery in case of a short circuit between power amplifier and battery. The fuse of the amplifier protects only the amplifier, not the vehicle battery.

Connection:

- Power-on indicator (Power/Protect)
- RJ 11 port for wired External Bass control
- Phase position
- Automatic switch-on
- Left loudspeaker input
- Right loudspeaker input / Preamplifier inputs
- 10 A fuse
- + Battery
- Remote connection
- Ground
- Bass boost
- Upper cut-off frequency
- Input sensitivity

Voltage supply

- We recommend a minimum cross section of 10 gauge
- Route commercially available OFC cables to the battery and connect via a fuse holder.
- Use cable glands for holes with sharp edges.

- Securely fasten commercially available negative cables to a noise-free ground point (chassis screw, chassis metal) (not to the negative terminal of the battery).
- Scrape the contact surfaces of the ground point on the body of the vehicle until they are bright and grease with graphite grease.

Power cable is connected to the positive pole of the battery and the Negative connection to vehicle ground. The input of the TWb 1000A should ideally be a two-channel (L+R), either via the preamplifier outputs of the head unit or the loudspeaker output of the factory audio system.

Integrated fuse

The fuse integrated in the amplifier section protects the output stage and the entire electrical system in case of a malfunction. If a replacement fuse is used, never bridge fuses or replace them with a type with higher current.

Audio inputs

You can select between 2 different audio inputs;

- Cinch (RCA)
- Hi-level (loudspeaker connections)

Use either of the two options listed above, never both of the audio inputs.

The preamplifier output from the head unit are connected to the cinch (RCA) sockets of the subwoofer box via a shielded RCA cable.

With input via the loudspeaker outputs, the input connections of harness are fed to the closest loudspeaker cables (front or rear) on the left and right.

They are separated and connected to the input connections on the harness. The polarity of the + or - connections must be observed.

Switching on/off

A special feature of the TWb 1000A is its automatic switch-on via DC OFFSET (High-level input only)

REM

Switching on/off via the car audio system The remote-in connection of the TWb 1000A must be connected with a switchable 12V power supply (e.g. switching output of the car audio system).

DC OFFSET*

Switching on/off via High-Level input connection only.

AUDIO*

Switching on/off via cinch connectors (RCA).

* The subwoofer box automatically switches on if a music signal is received. If no music signal is received for more than 60 seconds, the TWb 1000A automatically switches off.

GAIN control

The GAIN control is used to adjust the input sensitivity of the power amplifier to the output voltage of your car sound system preamplifier output.

The adjustment range is from 0.15V to 5V.

If an after-market audio system is connected, the input sensitivity of the amplifier must be adjusted corresponding to the manufacturer data of the radio selected.

A few important explanations in this context: By turning the control clockwise, the input sensitivity of the amplifier and, therefore, also the volume increases. However, this is not a volume control, no further amplifier output can be achieved in the end position, even if it may sound like that at the beginning. The system merely increases the volume faster if the volume control of the car sound system is turned up.

Bass boost

The BASS BOOST control is used to adjust the bass response of the amplifier.

The adjustment range is from 0dB - +12dB centered at 45Hz

The Bass Boost control can also be operated via the supplied wired Bass Controller. For this purpose, the external bass controller must be connected to the REMOTE LEVEL socket of the TWb1000A. As long as the External remote control is connected, changes made with the Bass Boost control of the subwoofer box have no effect.

Phase Control:

To help sync the subwoofer audio with the overall sound in a car cabin, the option to select from either 0-180° is provided. It's recommended to listen to the overall audio with the subwoofer connected at 0° and then switch to 180° and listen to the overall audio from the system. Selection can be made based on the overall audio response from the speakers and subwoofer.

X-OVER frequency control

The X-OVER control allows setting the desired frequency.

Example: At a setting of 150 Hz, the amplifier has a frequency range of 25 Hz to 150 Hz. It's recommended to position this control at 80-90 Hz

Power-on indicator (PWR / PRO)

Green LED: Output stage on, regular operating status.

Red LED: Output stage is electronically switched off due to an error.

Recycling and disposal



Please use the return and collection systems available to dispose of the product.

Subject to changes

Specifications:

- Powered subwoofer in a compact sealed enclosure
- 10" (250mm) Subwoofer
- Class D amplifier: 120 watts RMS / 480 watts Max Power
- Frequency Response: 40-170Hz
- Variable Low-pass Crossover: 50-150Hz
- Switchable Phase Control: 0-180°
- Bass Boost Control: 0dB - +12dB
- Low / Speaker (High) level input
- Wired External Bass Controller included
- Dimensions (W x H x D) 500 x 320 x 170/100 mm

TWb 1000A

Wiring diagram

Warning!
Use only the included cable adapters to connect the device.

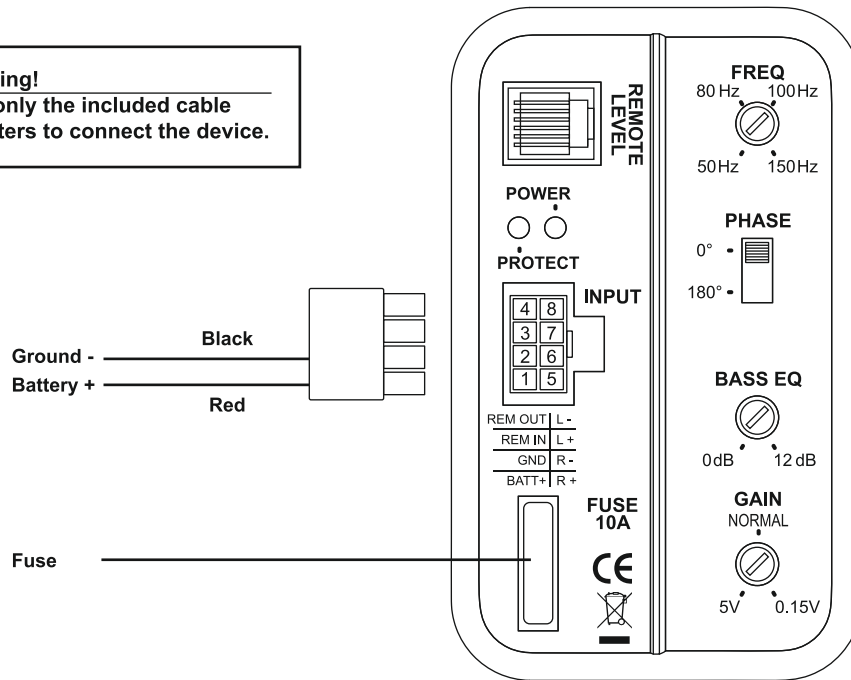

Auto turn-on function

Connect the blue/white cables to activate the auto turn-on function.

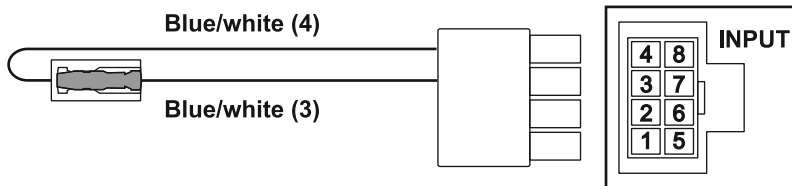

Turn-on by remote signal

Connect the blue cable with the remote output of the head unit/radio.

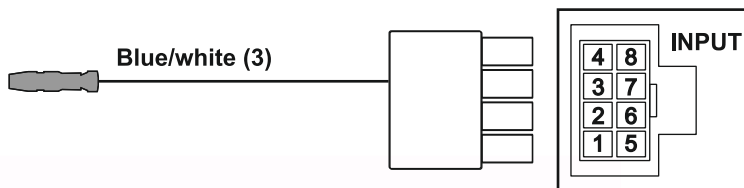

Signal input via RCA(low level)

Connect the RCAinputs with the appropriate pre-amplifier Outputs of the head unit/radio.

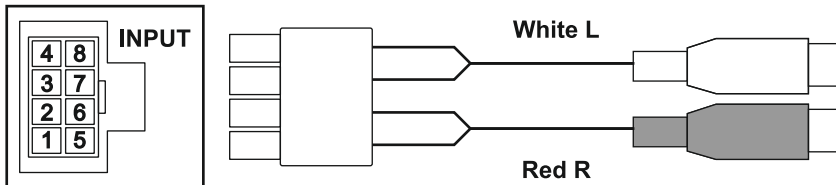

Signal input via speaker outputs (high level)

Connect the RCAinputs with the included RCA adapter and then connect the appropriate speaker outputs of the head unit / radio with its loosen ends.

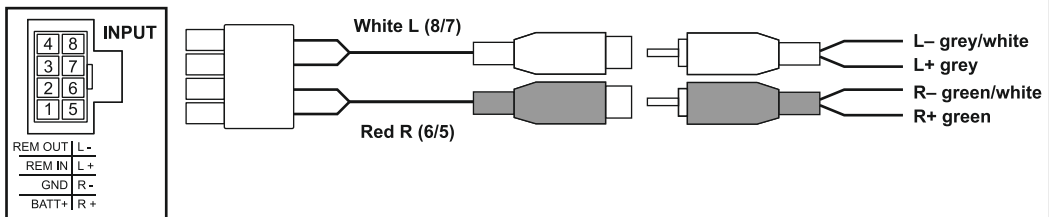

TWb 1000A



BPIN Private Limited
47, Atlanta Society, Nariman Point Mumbai- 400 021. India.
Toll Free: 1800 209 6820 | info@blaupunktcar.in
Shop Online at www.blaupunktcar.in